

Section 6.6 Polar Coordinates

Objective: In this lesson you learned how to plot points in the polar coordinate system and write equations in polar form.

Course Number

Instructor

Date

I. Introduction (Pages 493–494)

To form the **polar coordinate system** in the plane, fix a point O , called the _____ or _____, and construct from O an initial ray called the _____. Then each point P in the plane can be assigned _____ as follows:

1) $r =$ _____

2) $\theta =$ _____

In the polar coordinate system, points do not have a unique representation. For instance, the point (r, θ) can be represented as _____ or _____, where n is any integer. Moreover, the pole is represented by $(0, \theta)$, where θ is _____.

Example 1: Plot the point $(r, \theta) = (-2, 11\pi/4)$ on the polar coordinate system.

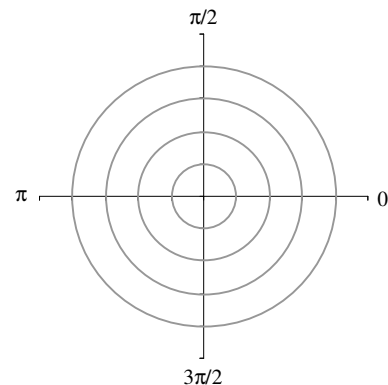

Example 2: Find another polar representation of the point $(4, \pi/6)$.

What you should learn

How to plot points on the polar coordinate system

II. Coordinate Conversion (Pages 494–496)

The polar coordinates (r, θ) are related to the rectangular coordinates (x, y) as follows . . .

What you should learn
 How to convert points from rectangular to polar form and vice versa

Example 3: Convert the polar coordinates $(3, 3\pi/2)$ to rectangular coordinates.

III. Equation Conversion (Page 497)

To convert a rectangular equation to polar form, . . .

What you should learn
 How to convert equations from rectangular to polar form and vice versa

Example 4: Find the rectangular equation corresponding to the polar equation $r = \frac{-5}{\sin \theta}$.

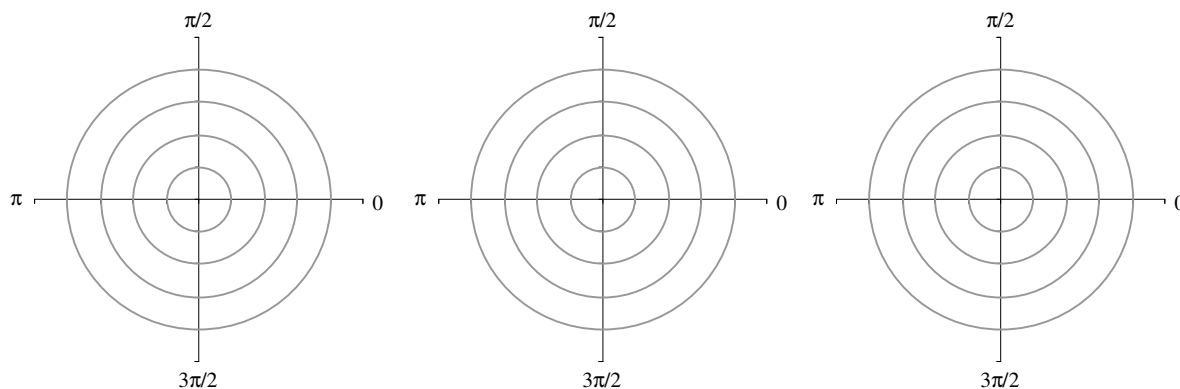

Homework Assignment

Page(s)

Exercises