

## Section 10.7 Polar Coordinates

**Objective:** In this lesson you learned how to plot points in the polar coordinate system and write equations in polar form.

Course Number

Instructor

Date

### I. Introduction (Pages 820–821)

To form the **polar coordinate system** in the plane, fix a point  $O$ , called the \_\_\_\_\_ or \_\_\_\_\_, and construct from  $O$  an initial ray called the \_\_\_\_\_. Then each point  $P$  in the plane can be assigned \_\_\_\_\_ as follows:

1)  $r =$  \_\_\_\_\_

2)  $\theta =$  \_\_\_\_\_  
\_\_\_\_\_

In the polar coordinate system, points do not have a unique representation. For instance, the point  $(r, \theta)$  can be represented as \_\_\_\_\_ or \_\_\_\_\_, where  $n$  is any integer. Moreover, the pole is represented by  $(0, \theta)$ , where  $\theta$  is \_\_\_\_\_.

**Example 1:** Plot the point  $(r, \theta) = (-2, 11\pi/4)$  on the polar coordinate system.

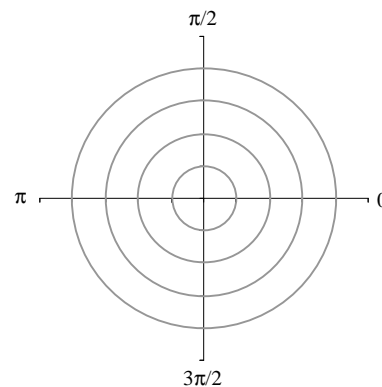

**Example 2:** Find another polar representation of the point  $(4, \pi/6)$ .

**What you should learn**  
How to plot points in the polar coordinate system

**II. Coordinate Conversion** (Pages 821–822)

The polar coordinates  $(r, \theta)$  are related to the rectangular coordinates  $(x, y)$  as follows . . .

***What you should learn***

How to convert points from rectangular to polar form and vice versa

**Example 3:** Convert the polar coordinates  $(3, 3\pi/2)$  to rectangular coordinates.

**III. Equation Conversion** (Page 823)

To convert a rectangular equation to polar form, . . .

***What you should learn***

How to convert equations from rectangular to polar form and vice versa

**Example 4:** Find the rectangular equation corresponding to the polar equation  $r = \frac{-5}{\sin \theta}$ .

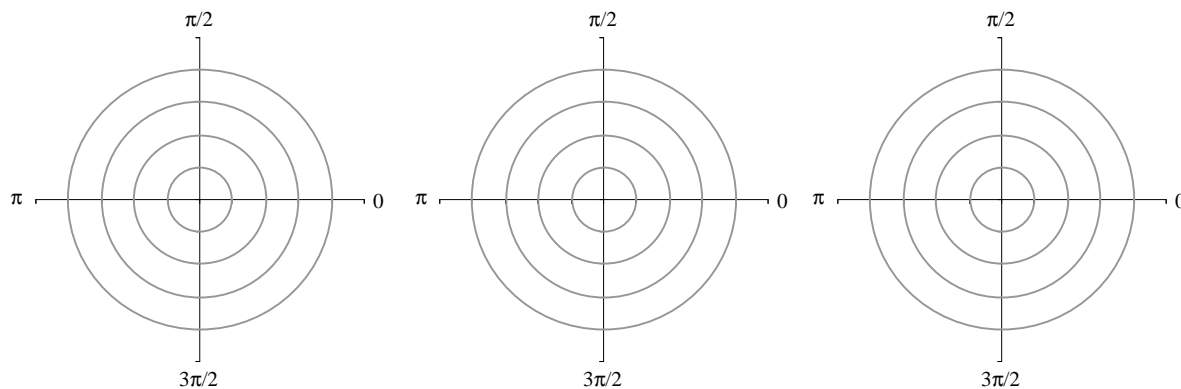
**Homework Assignment**

Page(s)

Exercises